

Please write clearly in block capitals.

Centre number

--	--	--	--	--

Candidate number

--	--	--	--

Surname

Forename(s)

Candidate signature

I declare this is my own work.

A-level PHYSICS

Paper 3 Section A

Thursday 15 June 2023

Morning

Time allowed: The total time for both sections of this paper is 2 hours. You are advised to spend approximately 70 minutes on this section.

Materials

For this paper you must have:

- a pencil and a ruler
- a scientific calculator
- a Data and Formulae Booklet
- a protractor.

Instructions

- Use black ink or black ball-point pen.
- Fill in the boxes at the top of this page.
- Answer **all** questions.
- You must answer the questions in the spaces provided. Do not write outside the box around each page or on blank pages.
- If you need extra space for your answer(s), use the lined pages at the end of this book. Write the question number against your answer(s).
- Do all rough work in this book. Cross through any work you do not want to be marked.
- Show all your working.

Information

- The marks for questions are shown in brackets.
- The maximum mark for this paper is 45.
- You are expected to use a scientific calculator where appropriate.
- A Data and Formulae Booklet is provided as a loose insert.

For Examiner's Use

Question	Mark
1	
2	
3	
TOTAL	



Section AAnswer **all** questions in this section.**0 1**

A stroboscope emits bright flashes of white light.
The duration of each flash and the frequency of the flashes can be varied.

Table 1 shows information about the stroboscope.

Table 1

	Minimum	Maximum
Duration of each flash / μs	60	300
Frequency of flashes / Hz	1	150

The duration of each flash is T_1 .

The time from the start of a flash to the start of the next flash is T_2 .

The duty cycle of a stroboscope is defined as $\frac{T_1}{T_2}$.

0 1 . 1

What is the maximum duty cycle of the stroboscope?

Tick (\checkmark) **one** box.

[1 mark]

6.0×10^{-5}

3.0×10^{-4}

9.0×10^{-3}

4.5×10^{-2}



0 1 . 2

Figure 1 shows images produced in an experiment in which a bouncing ball is illuminated by a stroboscope. The stroboscope flashes at a constant frequency.

Figure 1

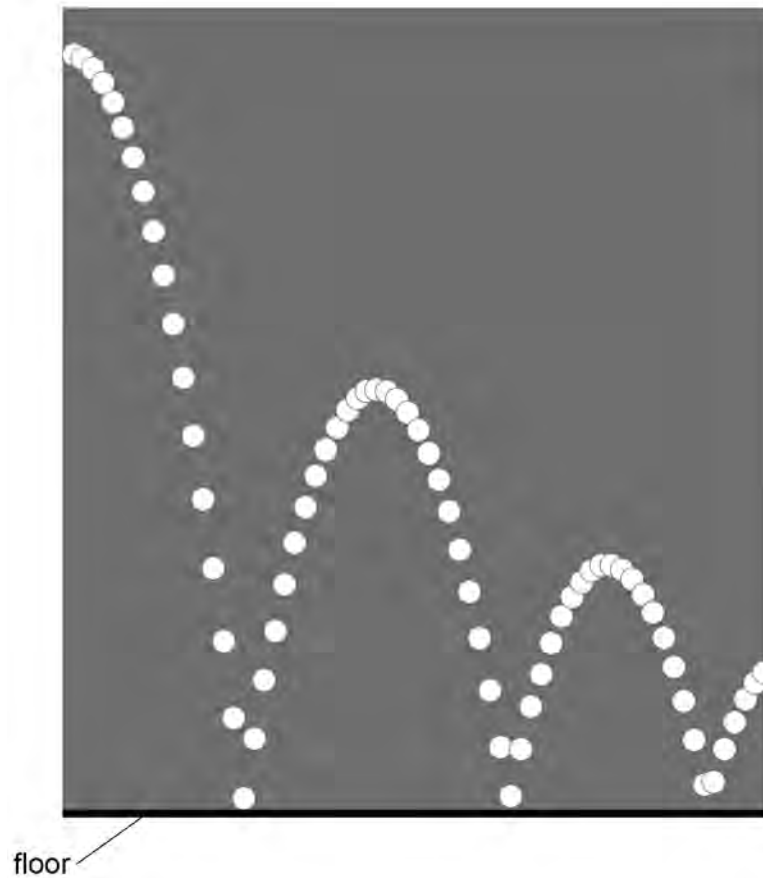

Suggest why T_1 must be very short for this experiment.

[1 mark]

Question 1 continues on the next page

Turn over ►



Figure 2 shows the first six images starting with $n = 0$, where n is the image number.

Figure 2

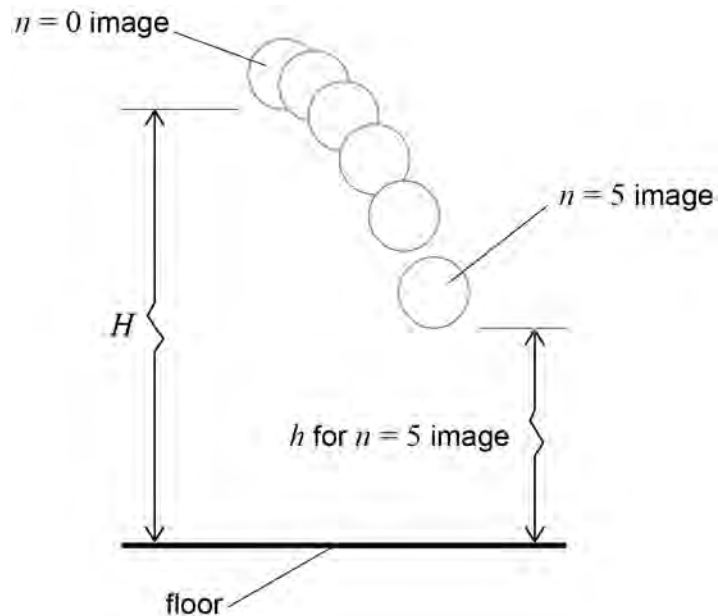

The images are used to determine:

H , the vertical distance from the bottom of the ball to the floor when $n = 0$

h , the vertical distance from the bottom of the ball to the floor for each non-zero value of n .

The $n = N$ image is produced at the instant that the ball hits the floor for the first time. For n between 0 and N it can be shown that

$$H - h = \frac{u_0 n}{f} + \frac{g}{2} \left(\frac{n}{f} \right)^2$$

where

u_0 is the vertical velocity of the ball when $n = 0$

g is the acceleration due to gravity

f is the frequency of the flashes.



0 1 . 3 In order to find g , a graph is plotted with values of $\frac{H-h}{n}$ on the y -axis.

Suggest what is plotted on the x -axis.
Go on to explain how g is determined from this graph.

[3 marks]

The following data are recorded.

$$H = 1550 \text{ mm}$$

$$f = 31.0 \text{ Hz}$$

The graphical analysis of data from **Figure 1** gives g as 9.79 m s^{-2} .

0 1 . 4 Determine u_0 .

[3 marks]

$$u_0 = \underline{\hspace{10em}} \text{ m s}^{-1}$$

Question 1 continues on the next page

Turn over ►



Figure 3 shows positions of the bottom of the ball for $n = 40$ to $n = 66$

In this range of positions, the ball makes contact with the floor for the second and third times.

Values of h , the vertical distance from the bottom of the ball to the floor, are plotted on the y -axis.

Values of s , the horizontal displacement from a point on the floor below the centre of the $n = 0$ image, are plotted on the x -axis.

Figure 3

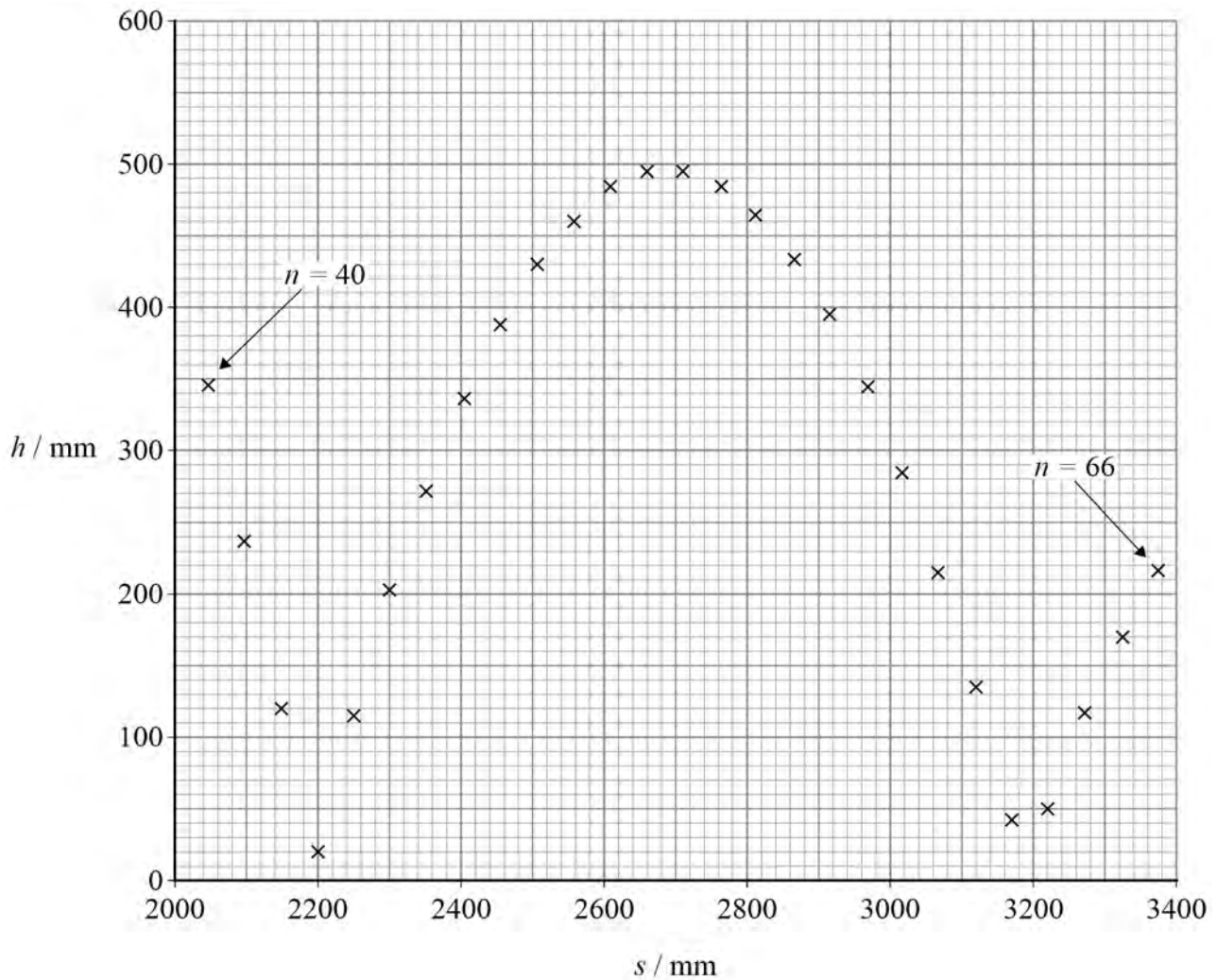

0 1 . 5

Determine, in mm s^{-1} , the horizontal velocity of the ball between the second and third contacts of the ball with the floor.

[2 marks]

horizontal velocity = _____ mm s^{-1}

0 1 . 6

Determine the time between the second and third contacts. Annotate **Figure 3** to show your method.

[3 marks]

time = _____ s

13

Turn over ►

0 2

Figure 4 is a plot of current–voltage data for a filament lamp L.

Figure 4

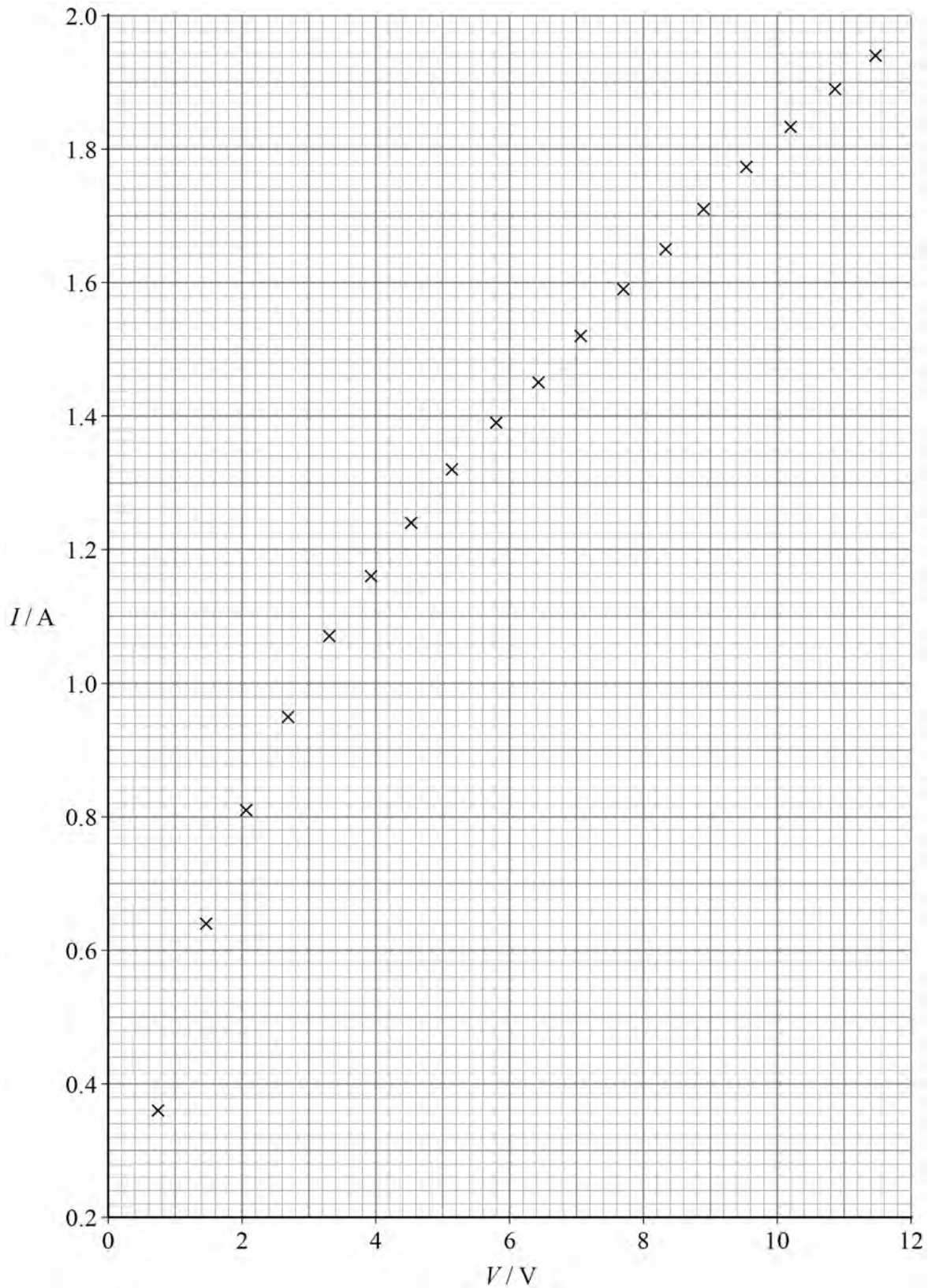

The current I was measured as the voltage V across L was increased at a steady rate.

These data were obtained using a current sensor and a voltage sensor connected to a data logger.

The logger recorded data at a rate of 2.5 Hz.

0 2 . 1 Determine, in V s^{-1} , the rate of increase of V .

[2 marks]

rate of increase of $V =$ _____ V s^{-1}

0 2 . 2 State **two** advantages of using data logging for this experiment.

[2 marks]

1 _____

2 _____

Question 2 continues on the next page

Turn over ►



0 2 . 3 Figure 5 shows two circuits that can be used to collect current–voltage data.

Figure 5

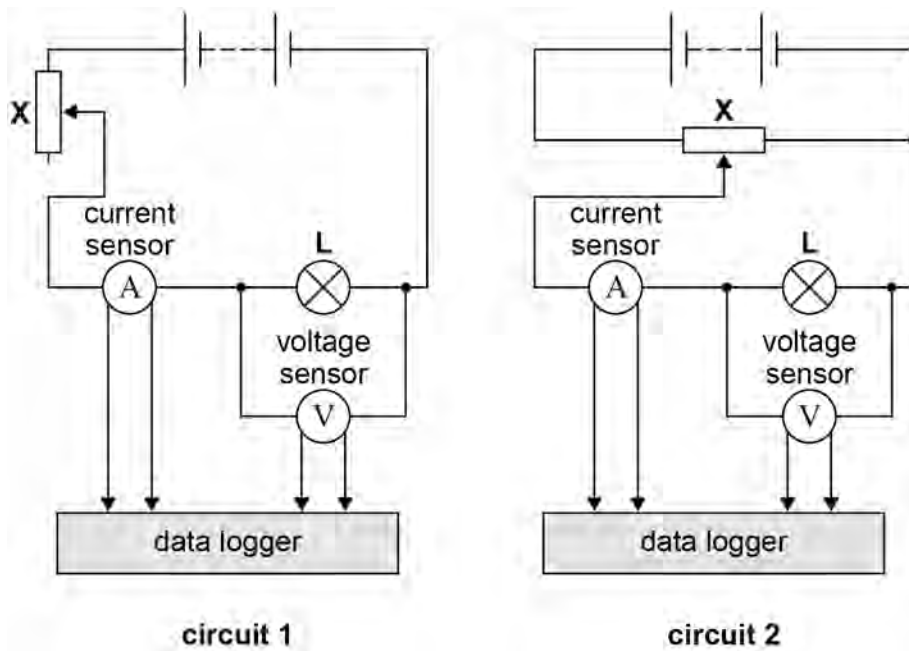

The dc supply has an emf of 12 V and negligible internal resistance. The current sensor and the voltage sensor behave as ideal meters.

In circuit 1:

- **X** is used as a variable resistor with a maximum resistance of 14.9Ω
- when **X** is set to maximum resistance, the resistance of **L** is 2.3Ω .

In circuit 2, **X** is used as a potential divider.



Discuss, with reference to circuit **1** and circuit **2**, whether either circuit can produce all the data shown in **Figure 4**.
Support your answer with a calculation.

[4 marks]

Question 2 continues on the next page

Turn over ►



Table 2 shows some values of V that are plotted on **Figure 4** and corresponding results for I and for the power P dissipated in L .

Table 2

V / V	I / A	P / W
3.30	1.07	3.53
5.17	1.32	
7.69	1.59	12.2
9.58		
11.47	1.94	22.3

0 2 . 4 Complete **Table 2**.

[3 marks]



0 2 . 5

Plot on **Figure 6** a graph of P against V .
You should use only the data in your completed **Table 2**.

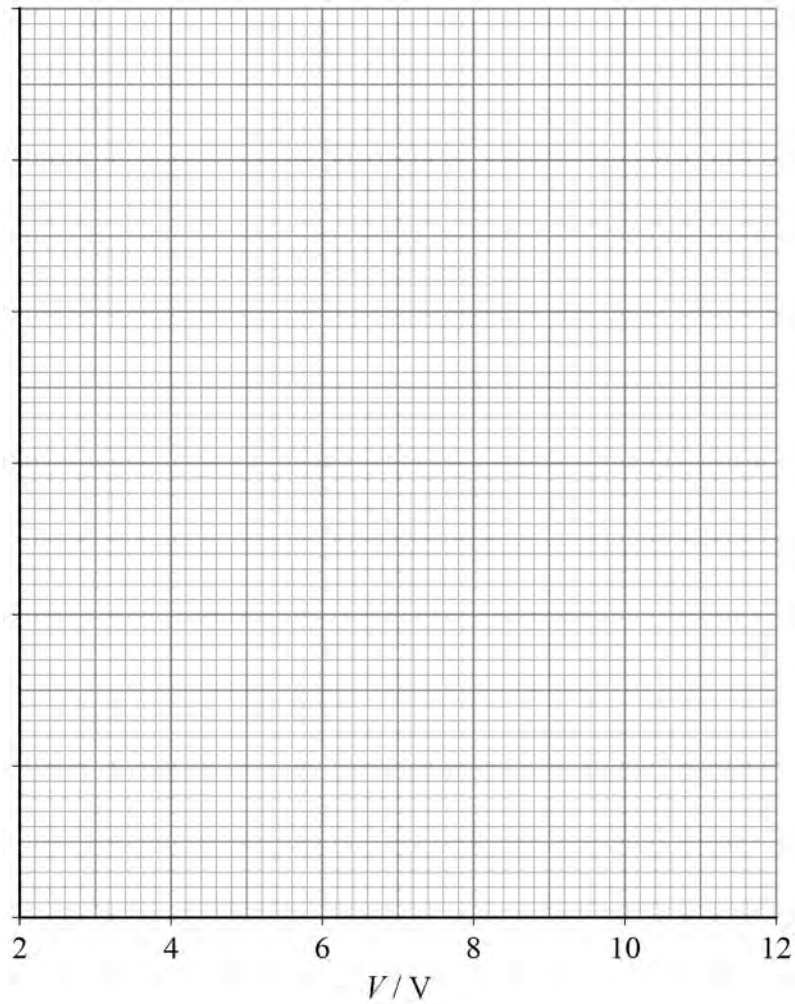
[3 marks]**Figure 6**

Question 2 continues on the next page

Turn over ►

0 2 . 6

L is connected to a 12 V power supply of negligible internal resistance.
L then dissipates its rated power P_r .

A second lamp, identical to **L**, is now connected in series with **L**.

Determine the percentage of P_r that is dissipated in this circuit.

[2 marks]

percentage = _____ %

16

0 3

Figure 7a shows the front view of a vertical coil mounted on a circular frame.

Figure 7b is a side view showing a section through the frame and coil. A constant direct current in the coil produces magnetic flux represented by the magnetic field lines on this diagram.

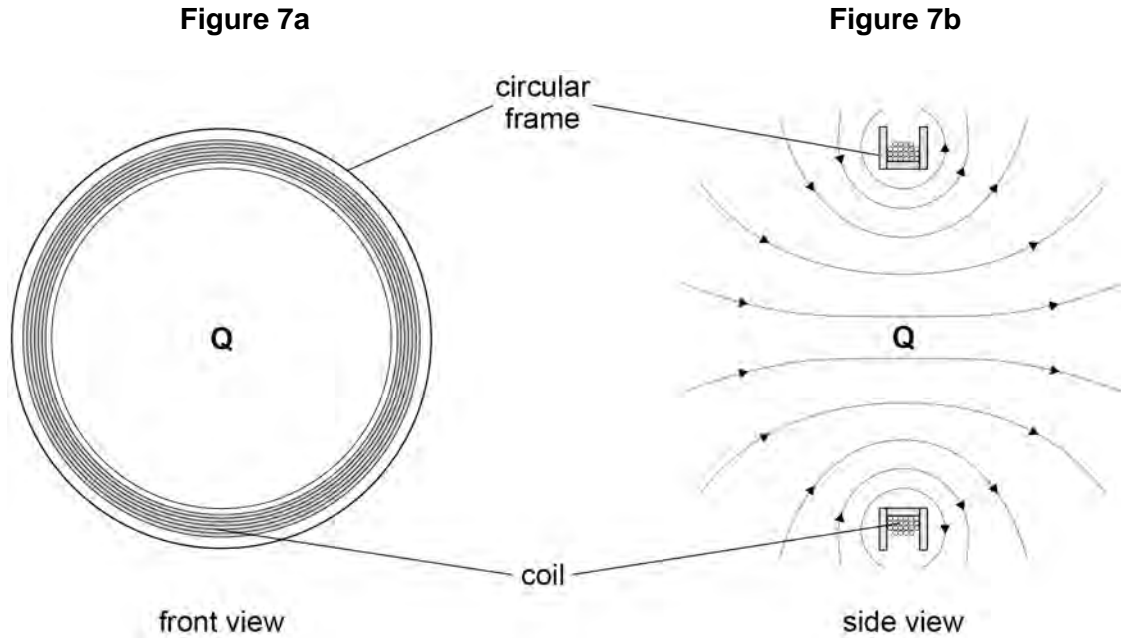

Point **Q** is at the centre of the coil.
 A sensor placed at **Q** detects B_H , the horizontal component of the magnetic flux density.
 The effect of the Earth's magnetic field at **Q** is negligible.

0 3 . 1

Discuss whether a search coil is a suitable sensor to detect B_H .

[2 marks]

Question 3 continues on the next page

Turn over ►



B_H is measured at **Q** with the coil vertical.

The coil is now rotated about **Q** through 25° as shown in **Figure 8**.
The current in the coil does not change.

Figure 8

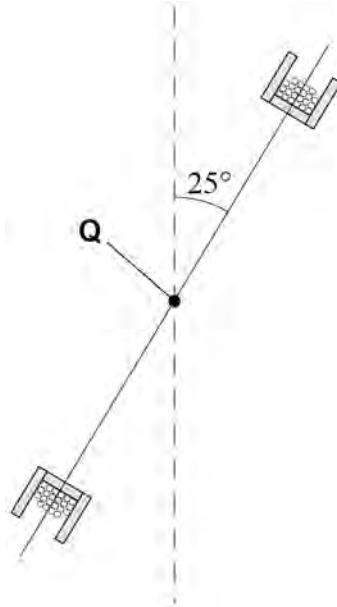

A new measurement of B_H is made with the coil fixed in this new position.

0 3 . 2 Determine the percentage change in B_H produced by this rotation of the coil.
Show your working.

[2 marks]

percentage change = _____ %



0 3 . 3

Figure 9 shows a protractor being used to measure the angle through which the coil is rotated.

Figure 9

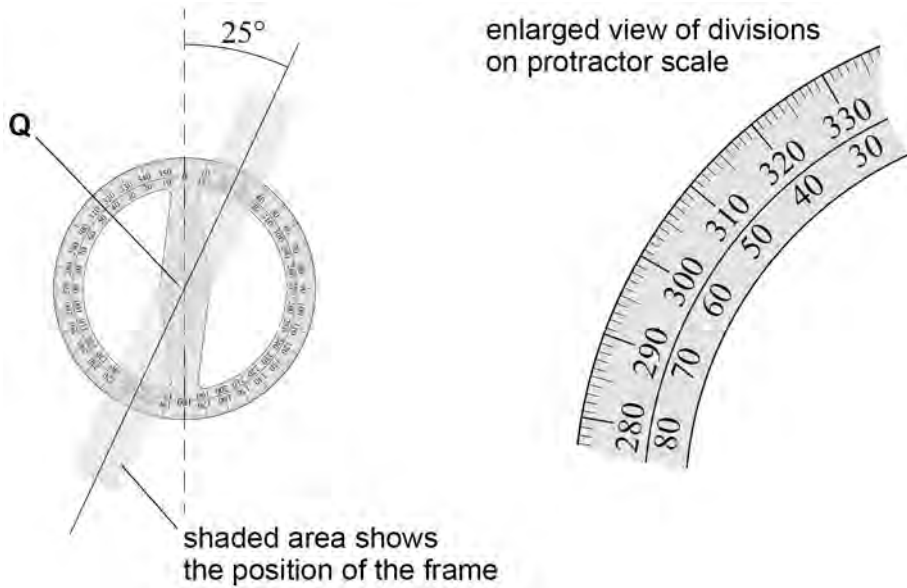

Estimate the percentage uncertainty in this result.
Justify your answer.

[3 marks]

percentage uncertainty = _____ %

Question 3 continues on the next page

Turn over ►



Figure 10 shows an arrangement of two vertical coils.
Four experiments are done using this arrangement.

Figure 10

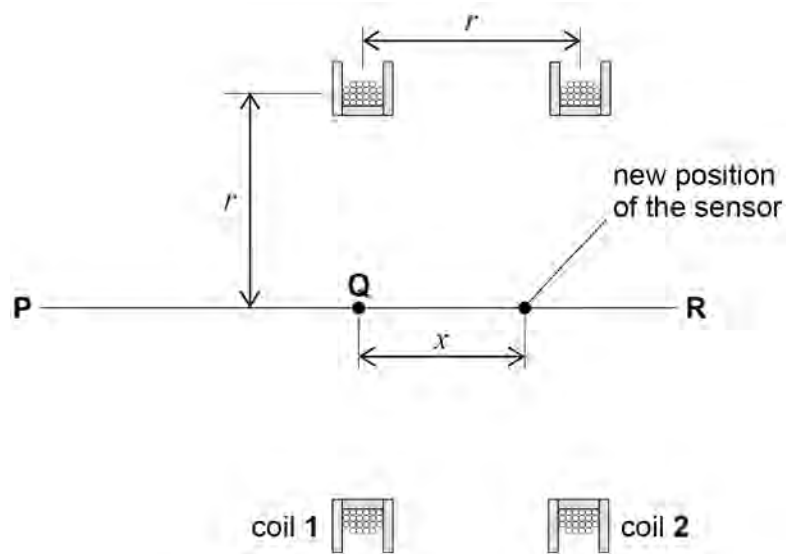

Coil 1 and coil 2 are identical and have a radius r .
The coils are separated by a distance r and have a common axis **PR**.
Q is at the centre of coil 1.

The four different experiments investigate how B_H varies with x , the displacement of the sensor from **Q** along **PR**.

In experiment 1, the current in coil 1 is 225 mA and the current in coil 2 is zero.

In experiment 2, the current in coil 1 is zero and the current in coil 2 is 225 mA.



Figure 11 shows the results of experiment 1 and experiment 2.

Figure 11

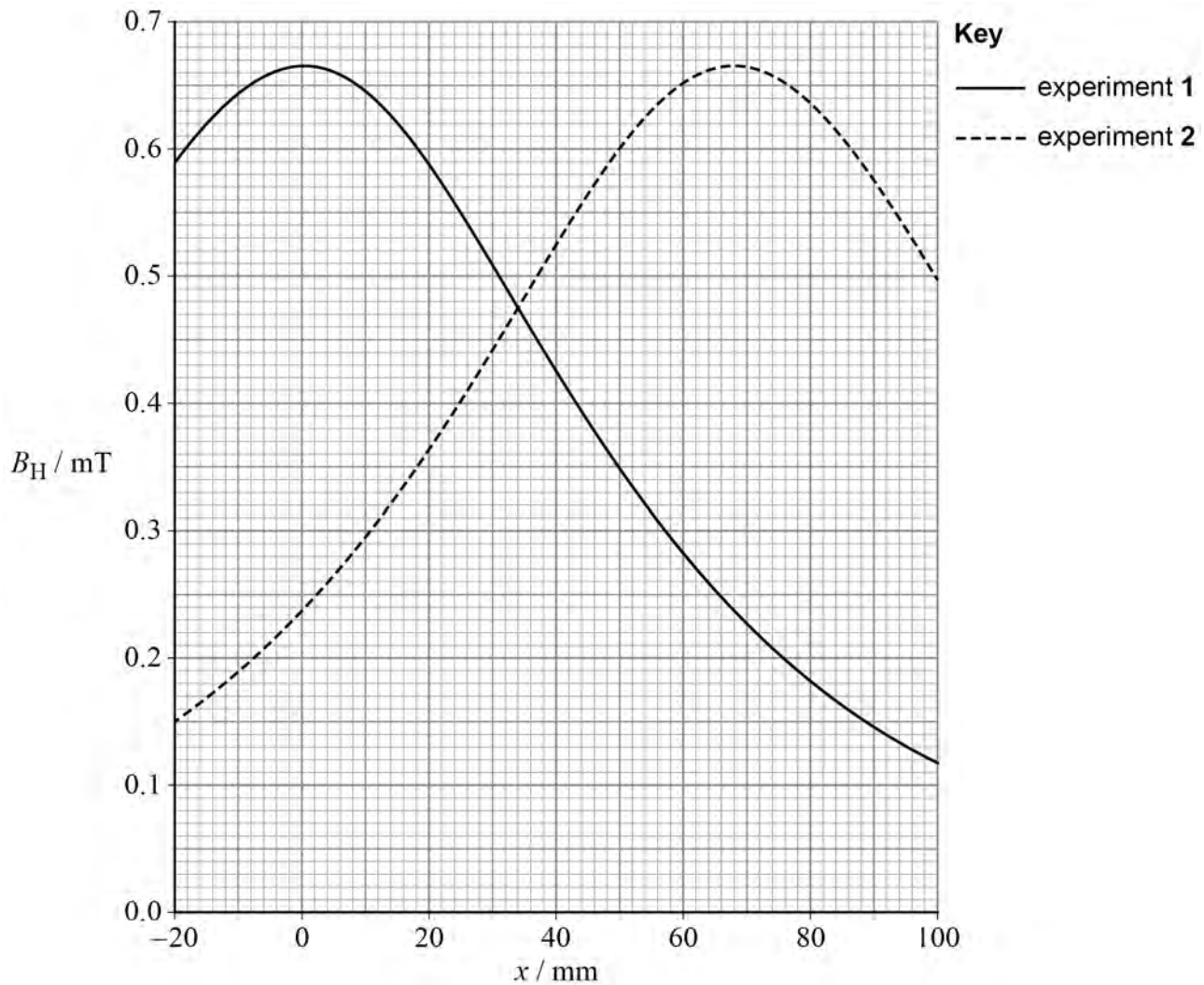

0 3 . 4 During experiment 1, B_H is measured with the sensor at **Q**.

The sensor is then moved along **PR** until the value of B_H is halved.

The distance from **Q** to the sensor is $x_{0.5}$

Determine $\frac{x_{0.5}}{r}$

[2 marks]

$$\frac{x_{0.5}}{r} =$$

Turn over ►



In experiment **3**, the current in both coils is 225 mA so that the magnetic fields produced by coil **1** and coil **2** are combined.

The resultant B_H has a constant maximum value in the region between $x = \frac{r}{4}$ and

$$x = \frac{3r}{4}$$

0 3 . 5 Deduce, in mT, the value of B_H in this region.

[2 marks]

$B_H =$ _____ mT

0 3 . 6 State **two** characteristics of the magnetic field lines in this region.

[2 marks]

1 _____

2 _____



0 3 . 7

In experiment 4, the current in coil 2 is reversed so that the direction of the magnetic field produced by coil 2 is also reversed.

The magnitudes of the currents in coil 1 and coil 2 are still 225 mA.

Sketch a graph to show how B_H varies between $x = 0$ and $x = r$.

The x -axis has been provided for you.

Your graph should include numerical values on your B_H axis that correspond to $x = 0$ and $x = r$.

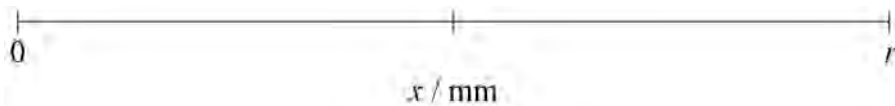
[3 marks]**END OF QUESTIONS**

There are no questions printed on this page

*Do not write
outside the
box*

**DO NOT WRITE ON THIS PAGE
ANSWER IN THE SPACES PROVIDED**



